

HPM601-C

High Frequency Partial Discharge Monitor



Designed for Diverse Utility and Industry Applications

HPM601-C High Frequency Partial Discharge Monitor



"Rugged Monitoring High Frequency Partial Discharge (PD) monitoring solution is a platform that enables HV asset owners to keep monitoring PD round the clock due to insulation defects.

System can also be used to perform online PD measurement during HV AC testing. Solution can communicate with its user over IEC61850 or using Rugged Monitoring proprietary Rugged Enterprise software suite. Shielded monitor with small dimensions make it easy to get installed and start.

Enhanced and newly added hardware and software features ensure highly sensitive multi-channel PD measurements for reliable, industry-standard PD testing on a variety of electrical equipment and components. System simple design enables it to get interfaced to third party protocols. Thousands of pulses per second can be transferred to the Server enabling the user to generate fast and reliable Phase Resolved Partial Discharge (PRPD) graphs. PRPD graphs help the user to identify type of PD in HV assets. Monitoring solution is packed with all necessary tools that help to perform effective PD measurements. Integrated variable amplifiers and on-board noise suppression features help during onsite testing even in case of presence of huge noise.

Rugged Monitoring's team of experienced condition monitoring specialists provide innovative testing, Diagnosis and Customized Monitoring Solutions.

Applications

- Online PD measurement during HV AC testing (Resonant test set, VLF, OWTS)
- Multiple point PD monitoring
- Cables and their accessories
- Rotating machines
- AIS/GIS switchgear/switchboards
- Power transformers

Features

- Rugged, simple design
- 4 synchronous input channels allow 3 phase synchronous measurement with additional external synchronous channel to enable the use of other type of sensor
- Rugged Enterprise, a complete software suite for analyzing the data and generating reports
- Indicator LEDs to alert in case of PD alarm or warning
- Gigabit ethernet copper Cat5e or multimode fiber communication link between monitor and server

Benefits

- Highly Efficient sensors, monitor and server
- Gigabit ethernet communication between monitor and Server
- Robust design parameters
- Each device is tested rigorously
- Software packed with useful tools for reliable and interactive PD measurements
- Robust recording and analytics
- Customizable according to customer specific applications
- Suitable for Online PD measurements

Technical Specifications

MONITOR	Channels	4 simultaneous channels 8 & 12 channel options available with multiplexer
	Sampling Rate	250 MS/s
	Bandwidth	0.01-100 MHz
	Amplification	up to 28 dB, software selectable
	Filtering	Software configurable band pass filters
MEMORY	SSD	upto 256 GB (Optional)
DATA TRANSFER	High Resolution (Pulses data on simultaneous channels)	10,000 pulses per second for 4 simultaneous channels
	Low Resolution (Pulse amplitude on simultaneous channels)	50,000 pulses per second for 4 simultaneous channels
	Transfer Rate	400 Mbps (depending on operating system and connection)
REMOTE COMMUNICATION	IEC61850 (Optional)	
	Proprietary Rugged Connect for remote communication	
	Customized third party interface on request	
COMMUNICATION LINK	Type	Ethernet Copper or Fiber (100/1000 BASE-T)
	Connector	RJ45 or LC Multi-mode
	IP Rating	IP65
TEMPERATURE RATING	Ambient	-30°C - 60°C
	Storage	-40°C - 85°C
POWER RATING	Input Power	100-240Vac, 45W
SYNCHRONISATION INPUTS	2 Inputs, software	Internal
	Selectable	External
DIMENSIONS	260mm(L)x310mm(W)x120mm(H)	
SOFTWARE	Rugged Enterprise	

Ordering Code

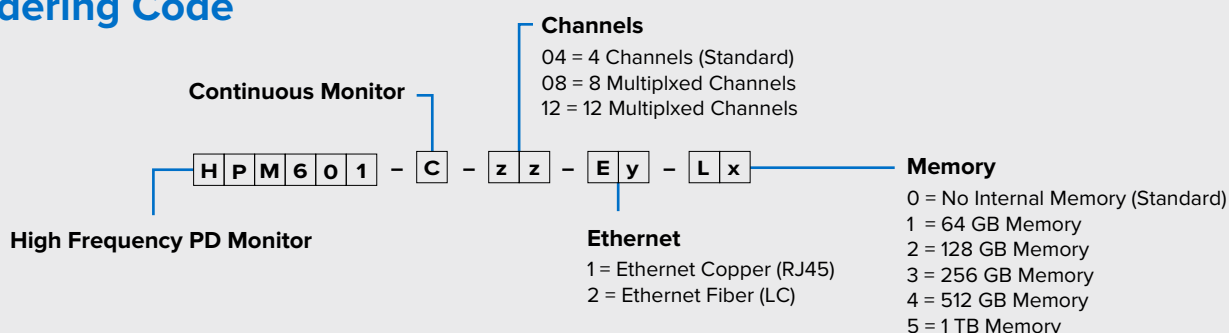

Asset Monitoring : Enterprise Architecture

Compatible with Rugged Monitoring Enterprise Solution

UI UX



- Data Layer
- Analytics
- User Interface
- Custom Dashboards
- Reporting
- Email/SMS Notifications

RM EYE

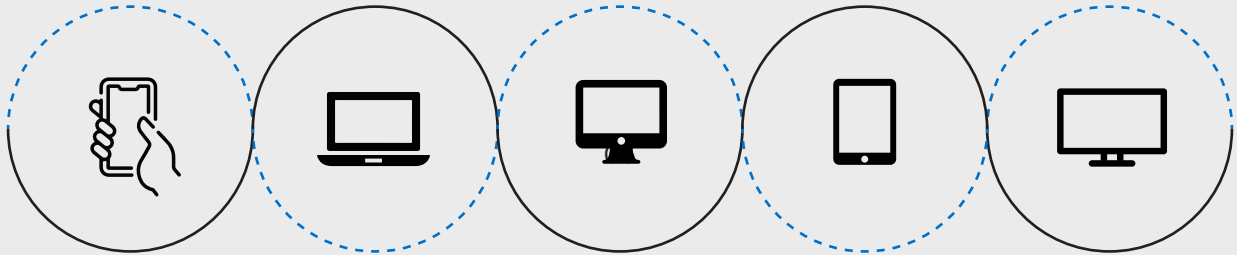

Private Cloud (Customer Cloud),
Rugged Monitoring Cloud

IEC 60870-104

IEC 61850

FTP/SFTP

- XML, JSON

- CSV, COMTRADE



Data Collection

ODBC

MODBUS

DNP 3.0

HTTPS

MQTT

Asset Data

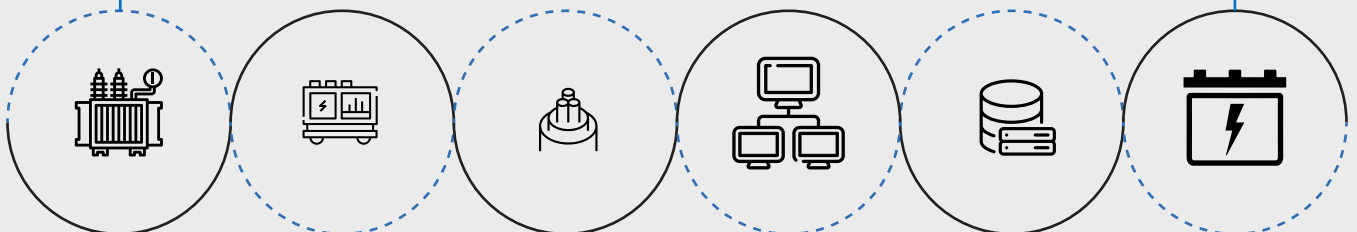

Transformer
Monitoring
System

Switchgear
Monitoring
System

Power Cable
Monitoring
System

- Offline Test Results
- Inspection Records
- Name Plate

- Historian
- CMMS
- SCADA/ DCS

Power Electronics
(Battery, UPS,
VFD, Relay)

One Solution for Multi-Site Multi Asset Monitoring

Manage different industrial assets on one platform without human intervention

Features

- **Advanced and Exceptional Reporting**
Technology with automated alerts
- **Modern remote monitoring solutions** provide valuable insights to Multiple Assets at Multiple Sites on real-time
- **Robust asset health monitoring** with analysis and recommendations support asset effectiveness in addition to maximizing equipment uptime
- **Establish a real time and consistent monitoring** by getting the right information into right hands
- **An efficient, reliable partial discharge monitoring** for all the assets
- **A detailed comprehensive DGA Analysis**
- **Lifetime Consumption details.**
- **Built on well-established remote and cloud-based monitoring technology**
- **Simple user-friendly interface** providing fast access to all the features and commands
- **Quick and easy 1 step configuration setup**
- **Encompasses a secure access to data and configuration**
- **Advanced asset algorithms** based on standard ones with new ideas
- **Systematic fleet management and analysis**
- **Extended multilingual support** to handle product inquires or troubleshoot problems proactively
- **Up System Level Reporting**
- **Industrial IoT**

Features Specific to PD Monitoring

- Partial Discharge monitoring and Analysis
- PRPD : Phase resolve partial discharge
- Partial Discharge Amplitude and Discharge rate trend analysis
- Partial Discharge Fault localization
- Artificial Intelligence based PD fault Identification
- Realtime PD Alarm system
- Get Alarm notifications for individual bushing parameters over Email, sms and push notifications
- Analytics on Online, and offline partial discharge test data

Why Customers Choose Us?

RM solution, the trusted monitoring solution for over 10000+ assets across 50+ countries. We are a leading High Value Electrical Asset Monitoring Company integrating fibre optic technology to the assets.



Attention to Details

It's our attention to the small stuff, scheduling of timelines and keen project management that makes us stand out from the rest.



A plan for Success

Our Customers are well satisfied with the advisory services that we offer to help them with best in class technological performance and a long durable life.



Experts only

We bring in our diversified experienced team with over 100+ years of experience in Asset Monitoring



Meeting Deadlines

Work with us, and you'll work with seasoned professionals – vigilant of deadlines, and committed to exceeding client expectations.



Money Matters

We protect you against currency fluctuation with competitive and fair market prices



Rugged Monitoring Services

Rugged Monitoring provides customization of sensors, monitors & software. In addition we offer on-site commissioning services, maintenance contracts and technical support to all customers worldwide.

About Rugged Monitoring

Industry's leading team of asset condition monitoring experts with 100+ years of combined experience committed to delivering customizable solutions for challenging applications. We offer a range of reliable, high performance, customizable sensors and monitoring solutions that are immune to external influence.

Certification



ISO 9001



ISO 14001



ISO 45001/
OHSAS 18000



Lloyd's
Register



ATEX
Certification

Our Presence Across the Globe



Head Office

 **Canada**

1415 Frank-Carrel, Suite
230, Quebec, QC - G1N
4N7, CANADA

 +1-418-767-0111

[Asia Pasific](#) | [India](#) | [Europe](#) | [Latin America](#) | [Middle East](#) | [North America](#)



 [ruggedmon](#)

 info@ruggedmonitoring.com

 www.ruggedmonitoring.com

©2021 Rugged Monitoring Company. All rights reserved. Information subject to change without notice. All trademarks are properties of their respective companies, as noted herein.