

RUGGED  **MONITORING**

MONITORING SIMPLIFIED

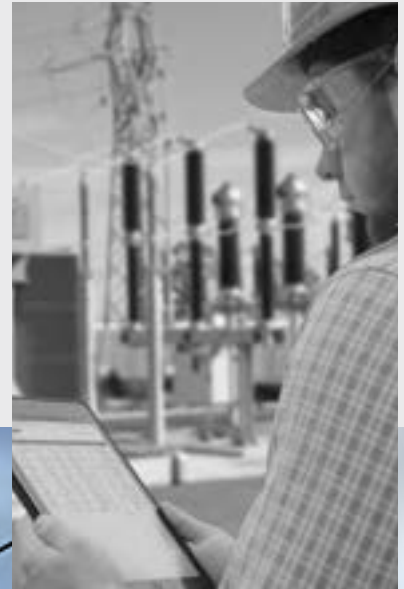

RUGGED

Bushing Monitoring

Cost-effective Solution for avoiding bushing failure

Bushing Monitoring Solution

Rugged Monitoring presents an advanced bushing monitoring solution that gives predictive diagnostics to help users prevent malfunctions or breakdowns in wide range of power transformer bushing equipment. Our self-operating system and remote monitoring solutions present real-time diagnosis and allow utilities to work towards solving problems rather than finding them.

Routine maintenance, early replacement and traditional off-line testing have been used to

address difficulties in bushing failures in the past. With the recent technology asset owners can detect failures and can directly reduce their maintenance downtime and costs.

We at Rugged Monitoring are motivated to provide innovative and exceptional quality products, our vision remains focused on meeting customer requirements while anticipating and exceeding the needs of a continuously changing dynamic market.



RM's Comprehensive Bushing Monitoring Solution

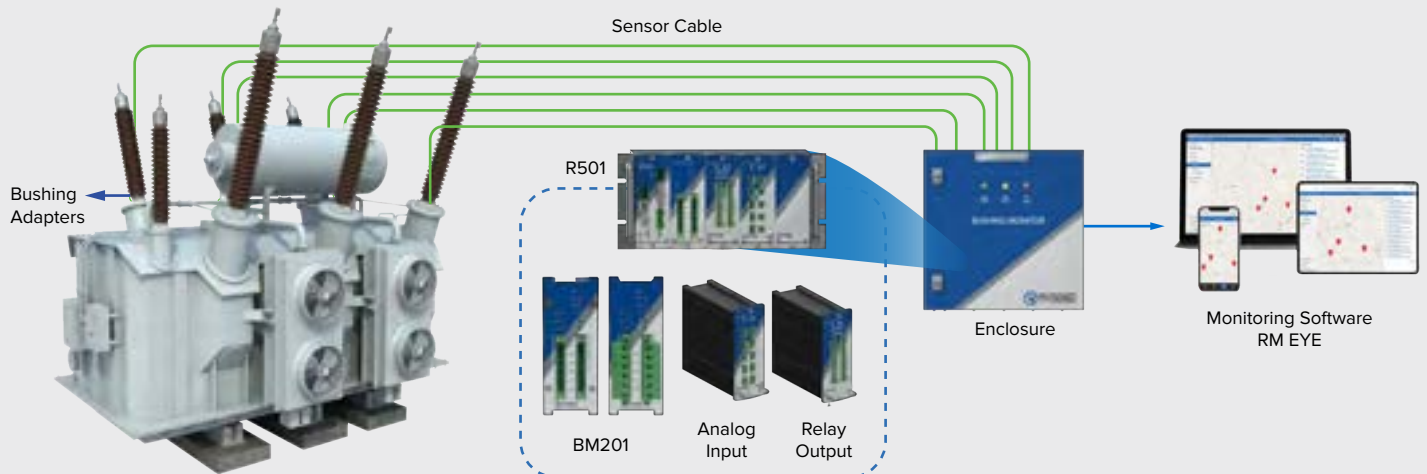

Option 1: R501 Comprehensive Electrical Asset Monitoring System

R501 comprehensive Transformer Monitoring system with integrated Bushing Module can be used as complete bushing monitoring solutions. The R501 can be expanded to add monitoring of temperature, Partial discharge, OLTC, Cooling System and Relay outputs.

Option 2: BM201 as a Standalone Bushing Monitoring Module

BM201 is a standalone single Module solution for up to 6 bushings. The Din-Rail mount module connects with the bushing adapters and provides serial Modbus output using RS-485 port.

- **Grid Reliability**

Maximize the grid reliability by locating downed conductors, monitoring, and addressing unplanned grid-edge transformer load and overload.

- **Maximum Uptime**

Can notify operators of power interruptions, enabling faster location of outages, and accelerating restoration.

- **Integrated Solution**

Monitors bushing conditions and detects PD activity in the main tank

- **Increased Value Proposition**

RM can offer its customers with a comprehensive bushing evaluation and monitoring package for new or retrofitting transformers

RM's Bushing Module Solution

3 Phase Transformer

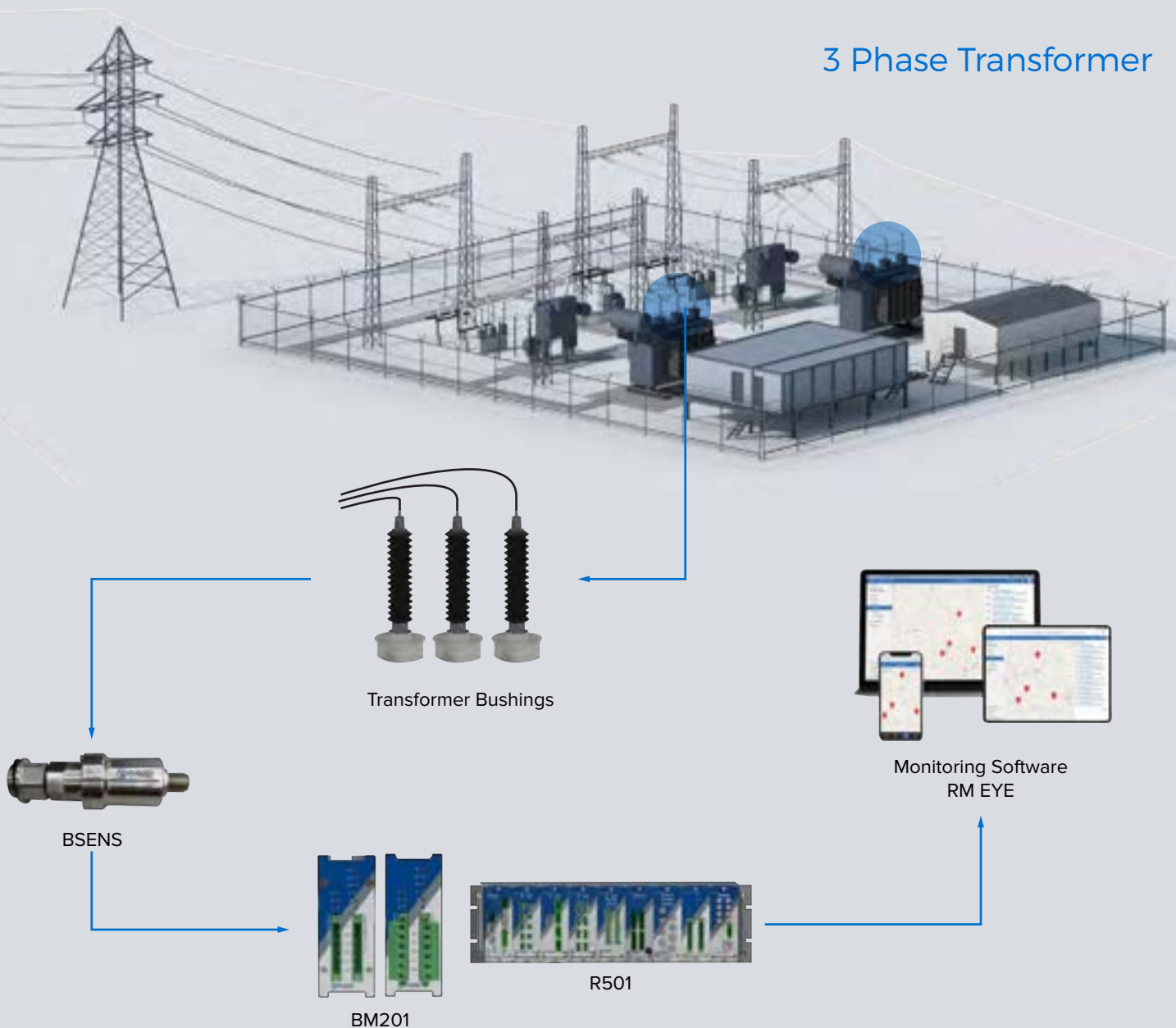

BSENS

Bushing Sensor for Improved Transformer Reliability to Avoid Bushing Failure



Bushing failures can be caused by transient overvoltage's, temperature fluctuations, as well as by the ingress of moisture, which can quickly lead to failure of bushing insulation or even to a major transformer failure.

Our BSENS continually perform online condition monitoring of transformer bushings through regular time-based diagnostics. Bushing adaptors are installed at the bushing test tap or voltage tap. Being a function of phase ground voltage and impedance of the bushing insulation, leakage current passes through the tap adaptors flowing to ground through capacitance, any imbalance in the impedance of the insulation will lead to variation in leakage current.

The measured leakage current from BSENS provides following outputs:

- Capacitance
- Tan δ or Dissipation Factor
- Partial Discharge Signals

Bushing Sensors for Tan δ and Capacitance monitoring are based on measuring Leakage Current in the range of 1mA to 200mA which also additionally provides HF signals between 100 kHz – 25 MHz for PD monitoring.

We at Rugged Monitoring have 45+ different bushing tap adaptors designed to cover most of the bushings aiding in faster system commissioning. Our standard sensors are designed for bushings with rated voltage of upto 1500 kV.

Benefits

- Easy installation and commissioning
- Flexible configuration options to meet customer expectations
- Generates highly accurate data
- Early incipient fault detection ensures reliable operation and reduces supply outages

Applications



Condensing/ capacitive type bushings



Transformer Bushings



Breaker Bushings



Features

- Reliable and robust product
- Measures leakage currents of fundamental harmonics
- Variants are available for monitoring up to 6 bushings on three phase transformers
- It measures High Frequency PD signals
- Based on industry standard method
- Most accurate condition analysis
- Custom designed for various bushing taps

Technical Specifications

ELECTRICAL SPECIFICATIONS	Transient Voltage Protection	Up to 1500 KV Bushings
	Bushing Tap Earthing Protection	Double Protection against any loss to grounding connection
	Sensor Output	Leakage Current = 1mA to 200mA Partial Discharge: 100 kHz to 25 MHz
	Recommended Cable	RG223 or RG213
	Measured Parameters	Leakage Current and Partial Discharge
MECHANICAL SPECIFICATIONS	Custom designed for various bushing taps	
ENVIRONMENTAL SPECIFICATIONS	Operating Temperature	-60°C to +95°C
	Storage Temperature	-40°C to +85°C
	Humidity	95% Relative Humidity
	IP rating	IP 66 (Protection against moisture ingress)

Ordering Code

BUSHING SENSOR- LEAKAGE CURRENT

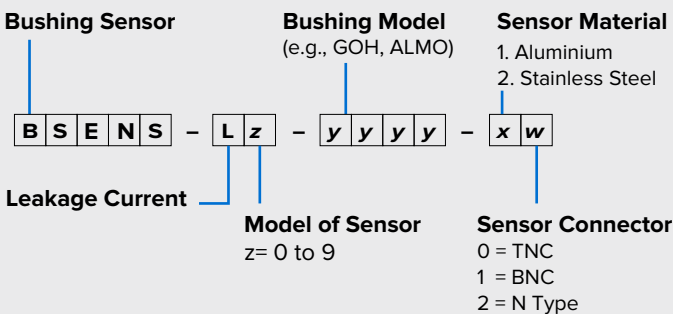

BUSHING SENSOR- PARTIAL DISCHARGE

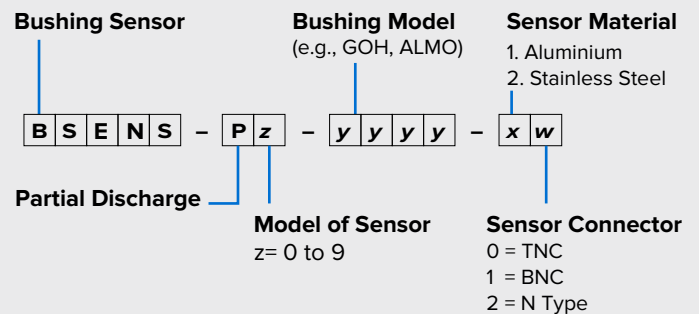

BM201 Rugged Bushing Monitoring Module for Industry Applications

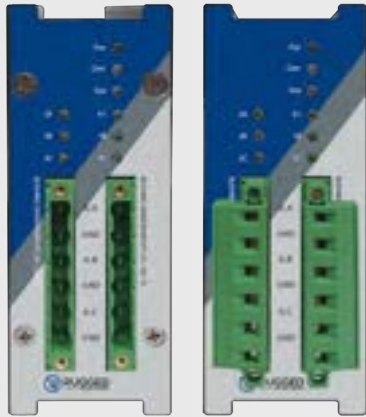

Rugged Monitoring BM201 is an online bushing monitoring module designed compactly to monitor real time condition of the Bushings.

Operating under high voltage substation environments with greater reliability BM201 measures Power Factor/Tan δ and Capacitance from the bushing test tap adaptors. It will alert personnel of fault conditions at an early stage and provide vital health information on the bushings and the transformer.

Providing a comprehensive view of the transformers bushing conditions BM201 combines accuracy and easy to

use software which can further be expanded to additional transformers. It is available as a standalone or comprehensive system integrated with other transformer monitoring solutions and can stably monitor maximum upto 6 bushings.

Using custom made adapters connected at the bushing tapping points, the BM201 by applying a proven balance current method (Sum of Current) measures

- The change in bushing leakage current compared with the original values correlated from the bushing name plate information.
- The timing difference between the 3 bushing current phases, which translates to phase angle differences relative to each other.

The measured and calculated values are then sent to the third-party system via Modbus (RTU) protocol using built-in serial (RS-485) port. The BM201 also captures the hourly average of the Tan δ , Capacitance and Voltage (absolute and rate of change). It has the data integration capability of multiple monitoring platforms.

Benefits

- Minimize asset outages due to bushing failure
- Efficient to avoid most dangerous catastrophic failures of bushings
- Optimize bushing replacement planning: RoC of Tan δ and capacitance.
- Cost optimized solution for different types of electrical asset
- Faster integration with SCADA or Cloud

Applications



Online monitoring of condensing/ capacitive type bushings



Online Monitoring of Transformer Bushings



Online Monitoring of Breaker Bushings

Features

- More than 45 + customizable bushing tap adaptors
- Highly accurate measurement for Tan δ and Capacitance
- Double protection for earthing link breakage
- Easy to install and commission
- Support for multiple technologies of bushing monitoring Sum of Current Method (Balance Current Method) and Reference Method

We at Rugged Monitoring have extensive experience and worldwide resources available to deliver integrated monitoring solutions and assist customers with transformer challenges, including various other electrical assets.

Technical Specifications

ELECTRICAL SPECIFICATIONS	Measurement Range Leakage Current	1mA to 200mA
	Leakage Current	$\pm 0.5\%$
	Tan δ (PF)	$\pm 0.5\%$
	Capacitance	$\pm 0.1\%$
	Voltage	$\pm 0.5\%$
	Scan Rate	-200 ms / channel
	Power Input	12 - 24V DC (Default)
	# of Relays Outputs	01 x Fail Safe Relay for System Failure
	Measured Parameter	Operating Voltage, Overvoltage, Leakage Current, Overcurrent
COMMUNICATION	Memory	MicroSD external memory slot (Up to 2 TB)
	Logging	1 sec interval on USB
	Serial Port	RS-485 with Modbus RTU
	Configuration Port	USB (to use with Rugged Connect windows software)
ENVIRONMENTAL SPECIFICATIONS	Operating Temperature	-25 °C to 75 °C
	Storage Temperature	-40 °C to 85 °C
	Humidity	95% Non-Condensing
MECHANICAL SPECIFICATIONS	Dimensions	4.92" x 4.92" x 1.89" (125mm x 125mm x 48mm)
	Number of Channels	Upto 06 channels

Ordering Code

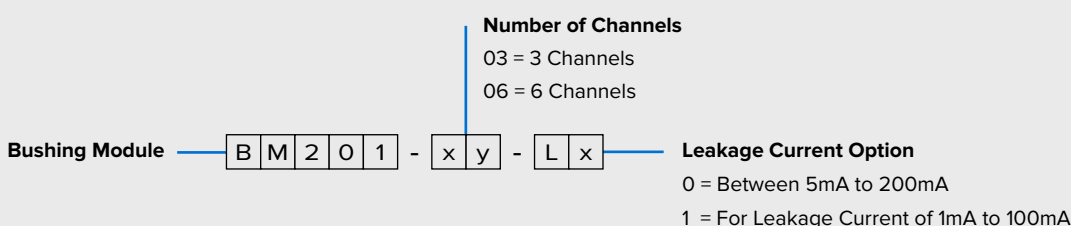

R501 Rack Mount Comprehensive and Customizable Transformer Monitoring Solution



Rugged, Most Versatile and Multi Channel monitoring solution capable of monitoring one or multiple transformers for :

Basic Transformer Monitoring, Fibre Optic temperature monitoring, Partial Discharge, Bushing, OLTC, Cooling System, Load, Power, and more...

Key Features

- Fully flexible rack mount and distributed architecture support
- Expandable & Field upgradable to add different transformer monitoring modules
- Highly secure, web server based visualisation and configuration software.
- Equipped with most accurate & advance transformer health assessment analytics
- Range of communication options and protocol support; Ethernet redundancy (PRP)
- Complies with the latest IEC/IEEE standards for Emission, Immunity, Safety and Environment.

Benefit

- Increased transformer availability
- Improved grid reliability
- Transformer lifetime extension
- Remote monitoring solution for various transformer parameters
- Lower cost of installation and maintenance - Higher RoI
- Faster integration with central condition monitoring system (On-Prem or Cloud)



R501 SYSTEM ARCHITECTURE

1. Transformer Control Cubicle

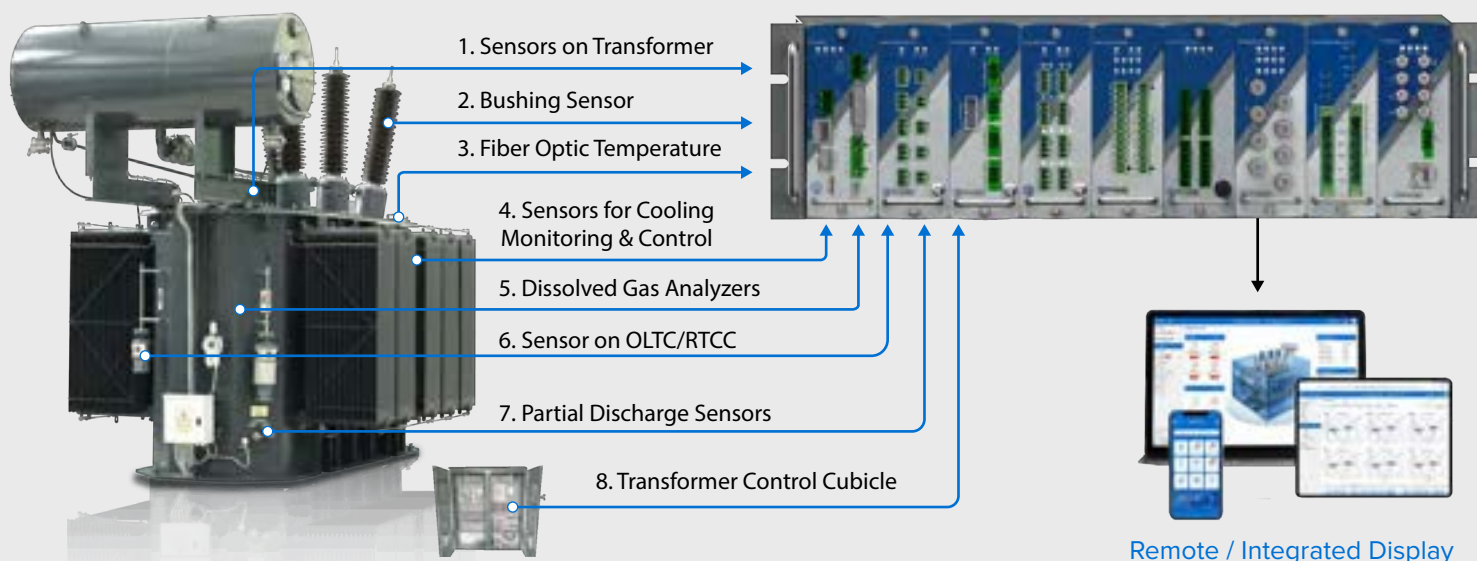

<p>1. Sensors on Transformer</p>	<p>2. Bushing Sensor</p>	<p>3. Fiber Optic Temperature</p>	<p>4. Sensors for Cooling Monitoring & Control</p>
<p>5. Dissolved Gas Analyzers</p>	<p>6. Sensor on OLTC/RTCC</p>	<p>7. Partial Discharge Sensors</p>	<p>8. Transformer Control Cubicle</p>

Sensors that can be connected to R501

- 1. OTI,WTI, RTD, PRD, Breather, Buchholz Relay, LLG/OLI, Pressure Sensor etc.
- 2. Range of Fibre Optic temperature monitoring sensors
- 3. Cooling System and Control Cabinet
- 4. Dissolved Gas Analyzer
- 5. Bushing adaptors and sensors
- 6. Range of Partial Discharge sensors

Certifications

<p>ATEX</p>	<p>Lloyds</p>	<p>CE / RoHs</p>
-------------	---------------	------------------

Variants

<p>Offshore / Marine</p>	<p>Ethernet Redundancy: PRP</p>	<p>Enterprise Monitoring Software</p>
--------------------------	---------------------------------	---------------------------------------

R501 Monitoring Modules

Comprehensive Features to Meet Market Demand

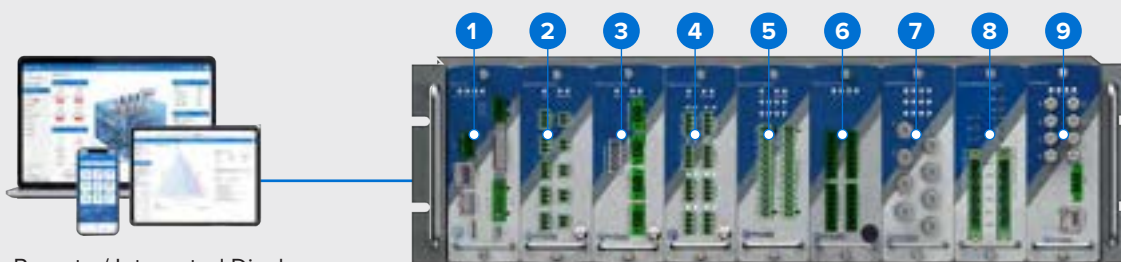

Remote / Integrated Display

1. CPU/GTW Module



Option A. CPU Module

- Data Processing & Storage
- System Fault Relay
- 01 x Serial (RS485) ports
- 02 x Ethernet (PRP support)
- Health Assessment Analytics

Option B. CPU with GTW

- Main rack with CPU, Slave rack with GTW
- Provides power to all modules
- Up to 4 Racks can be daisy chained
- 01 x Serial (RS485) ports

Option C. GTW without CPU

- Main rack and slave racks with GTW
- Provides power to all modules
- Supports FOM and FLM modules
- Up to 4 Racks can be daisy chained
- 01 x Serial (RS485) ports

2. Analog Input Module



- 05 or 10 channels
- AC/DC current input
- RTD / Potentiometer
- Built-in LED indicators

3. Power Monitoring Module



- 03 Current & 03 Voltage Inputs
- Active, Reactive & Apparent Power
- Transformer Power Factor
- Through-Fault Monitoring (I2T)
- Current Signature Analysis
- OLTC Motor Torque

4. Digital Input Module



- 08 or 16 channels
- Input Voltage 75 - 250Vdc
- Threshold Voltage > 60V
- Built-in LED indicators

5. Relay Output Module



- 04 or 08 Form C Relays
- Dry contact (NO-C-NC)
- User Programmable
- Built-in LED indicators

6. Analog Output



- 08 or 16 Analog output
- DC Current Loop (4-20mA / 0-1mA)
- Dc Voltage (0-5V / 0-10V)
- User Programmable
- Built-in LED indicators

7. Fiber Optic Module



- 02, 04, 06 and 08 Channels
- GaAs (200u and 62.5u) Module
- Fluro Module
- Built-in LED indicators

8. Bushing Monitoring Module



- 03 or 06 Channels
- Leakage Current
- Tan Delta / Power Factor
- Capacitance
- Phase Voltage
- Custom Tap Adaptor for Different Bushing

9. Partial Discharge Module



HF

UHF

- 04 or 08 Channels Continuous Monitoring
- Wide Range (HF and UHF)
- Sampling 100 MS/s
- Vertical Resolution 12bit
- Advanced PD Analysis
- UHF, Acoustic, Bushing PD Sensors available

Technical Specifications

POWER SUPPLY	Input Power Requirement	24 - 48 V DC (Default), 120 W, and any other (upon request)
CPU MODULE	Data Storage Capacity	MicroSD external memory slot (up to 2 TB)
	Logging Rate	1 sec interval on USB
	Config port	USB (to use with Rugged connect windows software)
SYSTEM CAPACITY	Maximum number of Channels	Expandable to 256 Channels, Daisy chain up to 32 units (with Modbus, Canbus)
FIBER OPTIC MODULES	# of Channels	2, 4, 6 and 8 channels
	Measurement Range	-80 °C to +300 °C (cryogenic 4 °K range optional)
	Resolution	0.1 °C
	Accuracy	±1.0 °C (±0.2 °C in relative temperature)
	Scan Rate	200 ms / channel (Optional: Faster scanning rates available)
ANALOG INPUT MODULE	# of Input Channels	05 or 10 Channels
	AC Current Input	Clamp-on CT with different ranges: 5Amp, 10Amp, 20Amp, 100Amp and others available
	DC Current Input	4 - 20 mA
	Temperature Input	100 ohm platinum (Pt100)
	Potentiometer	up to 20,000 ohms
POWER MONITORING MODULE	# of Input Channels	03 Current and 03 Voltage
	Current Input Range	0 - 5A
	Voltage Input Range	0 - 250V
	Sampling Rate	32 KS/s
	Measurement Parameters	Power, Through-Fault, Motor Torque etc.
DIGITAL INPUT MODULE	# of Input Channels	08 or 16 Channels
	Dry Contact	Resistance between the contact < 100 Ω
	Powered Contact	75 - 250Vdc
ANALOG OUTPUT MODULE	# of Input Channels	08 or 16 Channels
	Output format	4-20 mA or 0-5V or 0-10V Configurable for any measured / calculated value
BUSHING MONITORING MODULE	# of Input Channels	03 or 06 Channels
	Leakage Current Range	1mA to 200mA
	Monitoring Parameters	Tan Delta (PF), Capacitance, Phase Voltage, Overvoltage, Overcurrent
PARTIAL DISCHARGE MODULE	# of Input Channels	04 or 08 Channels
	Acquisition Bandwidth	HPM: 0.01 - 100Mhz UPM: 100 MHz - 2 GHz
	Monitoring Parameters	PD Amplitude, Discharge Rate and PRPD
OUTPUT RELAY MODULE	# of Output Channels	04 or 08 Form C relays
COMMUNICATION OPTIONS	Ethernet Ports (RJ-45 & FO Ethernet)	Modbus, DNP3.0, IEC 60870-5-104, MQTT, IEC61850, PRP
	Serial Port	RS485 with Modbus support
	CANBUS Port	CANBUS Master/Slave support for Can Dataloggers

Asset Monitoring : Enterprise Architecture

Compatible with Rugged Monitoring Enterprise Solution

UI UX



- Data Layer
- Analytics
- User Interface
- Custom Dashboards
- Reporting
- Email/SMS Notifications

RM EYE

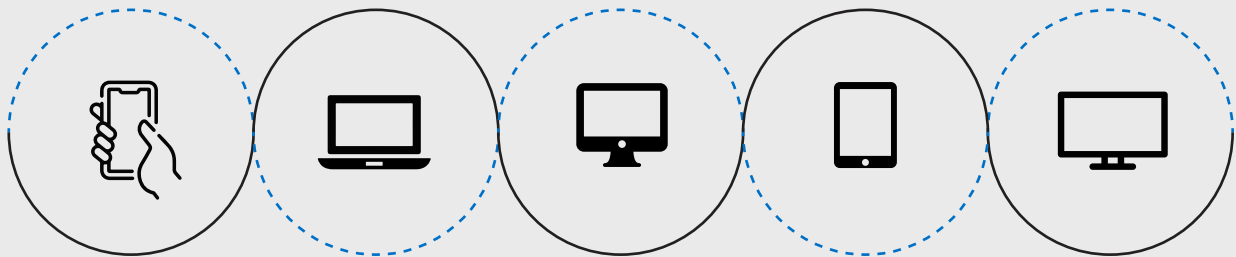

Private Cloud (Customer Cloud),
Rugged Monitoring Cloud

IEC 60870-104

IEC 61850

FTP/SFTP

- XML, JSON

- CSV, COMTRADE

Data Collection

ODBC

MODBUS

DNP 3.0

HTTPS

MQTT

Asset Data

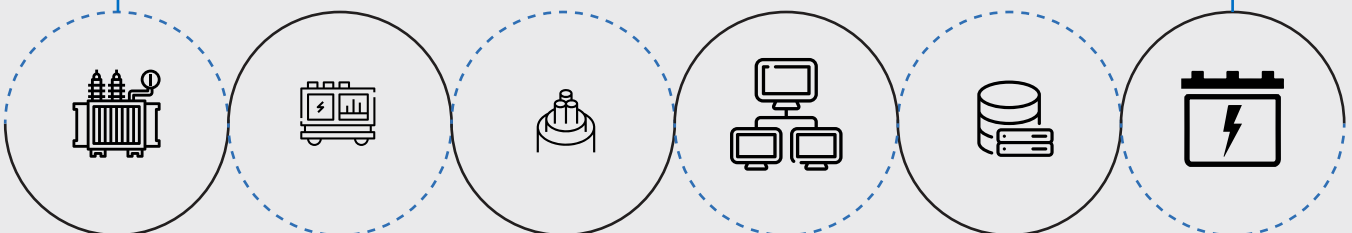

Transformer
Monitoring
System

Switchgear
Monitoring
System

Power Cable
Monitoring
System

- Offline Test Results
- Inspection Records
- Name Plate

- Historian
- CMMS
- SCADA/ DCS

Power Electronics
(Battery, UPS,
VFD, Relay)

One Solution for Multi-Site Multi Asset Monitoring

Manage different industrial assets on one platform without human intervention

Features

- **Advanced and Exceptional Reporting**
Technology with automated alerts
- **Modern remote monitoring solutions** provide valuable insights to Multiple Assets at Multiple Sites on real-time
- **Robust asset health monitoring** with analysis and recommendations support asset effectiveness in addition to maximizing equipment uptime
- **Establish a real time and consistent monitoring** by getting the right information into right hands
- **An efficient, reliable partial discharge monitoring** for all the assets
- **A detailed comprehensive DGA Analysis**
- **Lifetime Consumption details.**
- **Built on well-established remote and cloud-based monitoring technology**
- **Simple user-friendly interface** providing fast access to all the features and commands
- **Quick and easy 1 step configuration setup**
- **Encompasses a secure access to data and configuration**
- **Advanced asset algorithms** based on standard ones with new ideas
- **Systematic fleet management and analysis**
- **Extended multilingual support** to handle product inquires or troubleshoot problems proactively
- **Up System Level Reporting**
- **Industrial IoT**

Features Specific to Bushing Monitoring

- Bushing monitoring for HV, LV, and MV side
- Online and Periodic Capacitance & Tan delta analysis in the realtime
- Temperature monitoring with Sensors and Thermal cameras
- Get Alarm notifications for individual bushing parameters over Email, sms and push notifications
- Advanced DGA analysis for the Oil filled Bushings for fault identification
- Partial Discharge monitoring and Analysis
 - PRPD : Phase resolve partial discharge
 - Partial Discharge Amplitude and Discharge rate trend analysis
 - Partial Discharge Fault localization
 - Artificial Intelligence based PD fault Identification
- Analytics on Online, and offline test data

Why Customers Choose Us?

RM solution, the trusted monitoring solution for over 10000+ assets across 50+ countries. We are a leading High Value Electrical Asset Monitoring Company integrating fibre optic technology to the assets.



Attention to Details

It's our attention to the small stuff, scheduling of timelines and keen project management that makes us stand out from the rest.



A plan for Success

Our Customers are well satisfied with the advisory services that we offer to help them with best in class technological performance and a long durable life.



Experts only

We bring-in our diversified experienced team with over 100+ years of experience in Asset Monitoring



Meeting Deadlines

Work with us, and you'll work with seasoned professionals – vigilant of deadlines, and committed to exceeding client expectations.



Money Matters

We protect you against currency fluctuation with competitive and fair market prices



Rugged Monitoring Services

Rugged Monitoring provides customization of sensors, monitors & software. In addition we offer on-site commissioning services, maintenance contracts and technical support to all customers worldwide.

About Rugged Monitoring

Industry's leading team of asset condition monitoring experts with 100+ years of combined experience committed to delivering customizable solutions for challenging applications. We offer a range of reliable, high performance, customizable sensors and monitoring solutions that are immune to external influence.

Certification



ISO 9001



ISO 14001



ISO 45001/
OHSAS 18000



Lloyd's
Register



ATEX
Certification

Our Presence Across the Globe



Head Office

 **Canada**

1415 Frank-Carrel, Suite
230, Quebec, QC - G1N
4N7, CANADA

 +1-418-767-0111

[Asia Pasific](#) | [India](#) | [Europe](#) | [Latin America](#) | [Middle East](#) | [North America](#)



 [ruggedmon](#)

 info@ruggedmonitoring.com

 www.ruggedmonitoring.com

©2021 Rugged Monitoring Company. All rights reserved. Information subject to change without notice. All trademarks are properties of their respective companies, as noted herein.